

# DATA SHEET

## **74ABT657**

Octal transceiver with parity  
generator/checker (3-State)

Product data sheet  
Supersedes data of 1995 Dec 11

2004 Oct 27

# Octal transceiver with parity generator/checker (3-State)

74ABT657

## FEATURES

- Combinational functions in one package
- Low static and dynamic power dissipation with high speed and high output drive
- Output capability: +64 mA/−32 mA
- Power-up 3-State
- Latch-up protection exceeds 500 mA per JEDEC Std 17
- ESD protection exceeds 2000 V per MIL STD 883 Method 3015 and 200 V per Machine Model

## DESCRIPTION

The 74ABT657 high-performance BiCMOS device combines low static and dynamic power dissipation with high speed and high output drive.

The 74ABT657 is an octal transceiver featuring non-inverting buffers with 3-State outputs and an 8-bit parity generator/checker, and is intended for bus-oriented applications. The buffers have a guaranteed current sinking capability of 64 mA. The Transmit/Receive (T/R) input determines the direction of the data flow through the bidirectional transceivers. Transmit (active-HIGH) enables data from A ports to B ports; Receive (active-LOW) enables data from B ports to A ports.

The Output Enable ( $\overline{OE}$ ) input disables both the A and B ports by placing them in a high-impedance condition when the  $\overline{OE}$  input is HIGH. The parity select (ODD/EVEN) input gives the user the option of odd or even parity systems. The parity (PARITY) pin is an output from the generator/checker when transmitting from the port A to B (T/R = HIGH) and an input when receiving from port B to A port (T/R = Low). When transmitting (T/R = HIGH) the parity select (ODD/EVEN) input is set, then the A port data is polled to determine the number of HIGH bits. The parity (PARITY) output then goes to the logic state determined by the parity select (ODD/EVEN) setting and by the number of HIGH bits on port A. For example, if the parity select (ODD/EVEN) is set LOW (even parity), and the number of HIGH bits on port A is odd, then the parity (PARITY) output will be HIGH, transmitting even parity. If the number of HIGH bits on port A is even, then the parity (PARITY) output will be LOW, keeping even parity. When in receive mode (T/R = LOW) the B port is polled to determine the number of HIGH bits. If parity select (ODD/EVEN) is LOW (even parity) and the number of HIGHs on port B is:

- (1) odd and the parity (PARITY) input is HIGH, then  $\overline{ERROR}$  will be HIGH, signifying no error.
- (2) even and the parity (PARITY) input is HIGH, then  $\overline{ERROR}$  will be asserted LOW, indicating an error.

## QUICK REFERENCE DATA

SYMBOL	PARAMETER	CONDITIONS $T_{amb} = 25\text{ }^{\circ}\text{C}; \text{GND} = 0\text{ V}$	TYPICAL	UNIT
$t_{PLH}$ $t_{PHL}$	Propagation delay An to Bn or Bn to An	$C_L = 50\text{ pF}; V_{CC} = 5\text{ V}$	3.3	ns
$C_{IN}$	Input capacitance	$V_I = 0\text{ V or } V_{CC}$	4	pF
$C_{I/O}$	I/O capacitance	Outputs disabled; $V_O = 0\text{ V or } V_{CC}$	7	pF
$I_{CCZ}$	Total supply current	Outputs disabled; $V_{CC} = 5.5\text{ V}$	500	nA

## ORDERING INFORMATION

PACKAGES	TEMPERATURE RANGE	ORDER CODE	DWG NUMBER
24-Pin plastic SO	−40 °C to +85 °C	74ABT657D	SOT137-1
24-Pin Plastic SSOP Type II	−40 °C to +85 °C	74ABT657DB	SOT340-1
24-Pin Plastic DIP	−40 °C to +85 °C	74ABT657N	SOT222-1
24-Pin Plastic TSSOP Type I	−40 °C to +85 °C	74ABT657PW	SOT355-1

## PIN CONFIGURATION

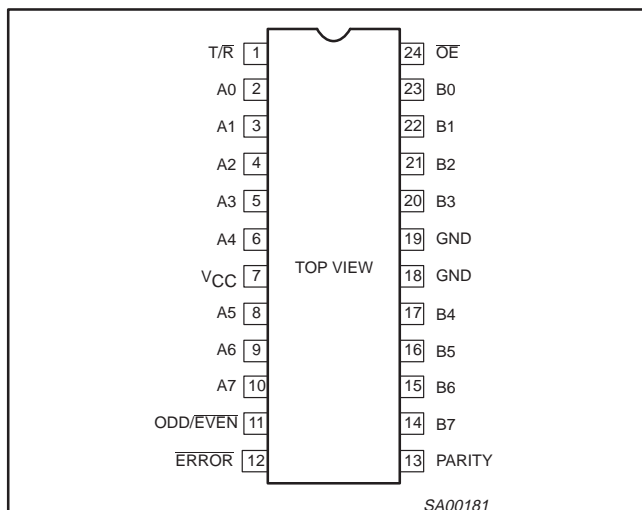

## PIN DESCRIPTION

SYMBOL	PIN NUMBER	NAME AND FUNCTION
13	PARITY	Parity output
11	ODD/EVEN	Parity select input
12	ERROR	Error output
1	T/R	Transmit/receive input
2, 3, 4, 5, 6, 8, 9, 10	A0 to A7	A port 3-State outputs
23, 22, 21, 20, 17, 16, 15, 14	B0 to B7	B port 3-State outputs
24	$\overline{OE}$	Output enable input (active-LOW)
18, 19	GND	Ground (0 V)
7	$V_{CC}$	Positive supply voltage

# Octal transceiver with parity generator/checker (3-State)

74ABT657

## LOGIC SYMBOL

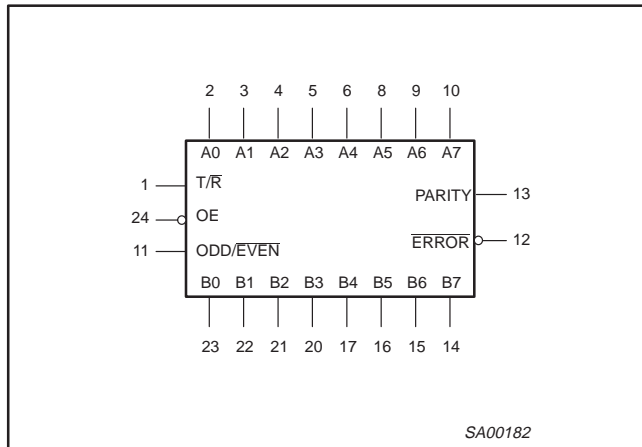

## LOGIC SYMBOL (IEEE/IEC)

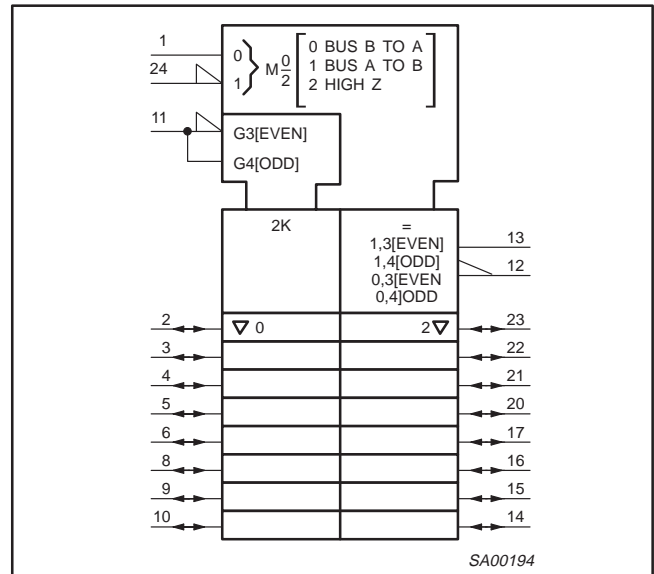

## FUNCTION TABLE

NUMBER OF HIGH INPUTS	INPUTS			INPUT/OUTPUT	OUTPUTS	
	OE	T/R	ODD/EVEN	PARITY	ERROR	OUTPUTS MODE
0, 2, 4, 6, 8	L	H	H	H	Z	Transmit
	L	H	L	L	Z	Transmit
	L	L	H	H	H	Receive
	L	L	H	L	L	Receive
	L	L	L	H	L	Receive
	L	L	L	L	H	Receive
1, 3, 5, 7	L	H	H	L	Z	Transmit
	L	H	L	H	Z	Transmit
	L	L	H	H	L	Receive
	L	L	H	L	H	Receive
	L	L	L	H	H	Receive
	L	L	L	L	L	Receive
Don't care	H	X	X	Z	Z	3-State

H = HIGH voltage level  
 L = LOW voltage level  
 X = Don't care  
 Z = High-impedance "off" state

# Octal transceiver with parity generator/checker (3-State)

74ABT657

## LOGIC DIAGRAM

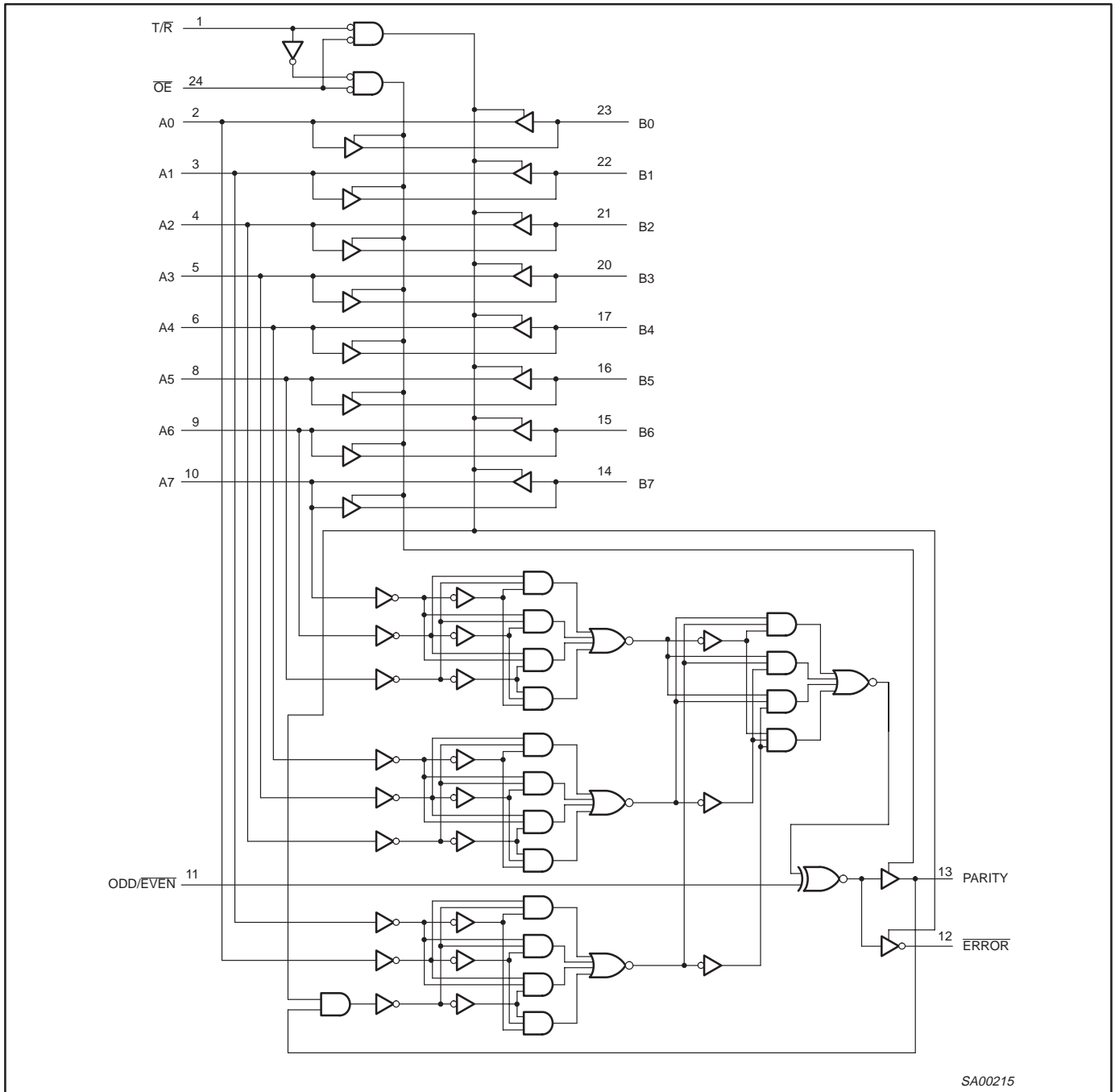

# Octal transceiver with parity generator/checker (3-State)

74ABT657

## ABSOLUTE MAXIMUM RATINGS<sup>1, 2</sup>

SYMBOL	PARAMETER	CONDITIONS	RATING	UNIT
$V_{CC}$	DC supply voltage		-0.5 to +7.0	V
$I_{IK}$	DC input diode current	$V_I < 0$ V	-18	mA
$V_I$	DC input voltage <sup>3</sup>		-1.2 to +7.0	V
$I_{OK}$	DC output diode current	$V_O < 0$ V	-50	mA
$V_{OUT}$	DC output voltage <sup>3</sup>	output in Off or HIGH state	-0.5 to +5.5	V
$I_{OUT}$	DC output current	output in LOW state	128	mA
$T_{stg}$	Storage temperature range		-65 to 150	°C

### NOTES:

- Stresses beyond those listed may cause permanent damage to the device. These are stress ratings only and functional operation of the device at these or any other conditions beyond those indicated under "recommended operating conditions" is not implied. Exposure to absolute-maximum-rated conditions for extended periods may affect device reliability.
- The performance capability of a high-performance integrated circuit in conjunction with its thermal environment can create junction temperatures which are detrimental to reliability. The maximum junction temperature of this integrated circuit should not exceed 150 °C.
- The input and output voltage ratings may be exceeded if the input and output current ratings are observed.

## RECOMMENDED OPERATING CONDITIONS

SYMBOL	PARAMETER	LIMITS		UNIT
		Min	Max	
$V_{CC}$	DC supply voltage	4.5	5.5	V
$V_I$	Input voltage	0	$V_{CC}$	V
$V_{IH}$	HIGH-level input voltage	2.0		V
$V_{IL}$	LOW-level input voltage		0.8	V
$I_{OH}$	HIGH-level output current		-32	mA
$I_{OL}$	LOW-level output current		64	mA
$\Delta t/\Delta v$	Input transition rise or fall rate	0	5	ns/V
$T_{amb}$	Operating free-air temperature range	-40	+85	°C

# Octal transceiver with parity generator/checker (3-State)

74ABT657

## DC ELECTRICAL CHARACTERISTICS

SYMBOL	PARAMETER	TEST CONDITIONS	LIMITS					UNIT
			T <sub>amb</sub> = +25 °C			T <sub>amb</sub> = -40 °C to +85 °C		
			Min	Typ	Max	Min	Max	
V <sub>IK</sub>	Input clamp voltage	V <sub>CC</sub> = 4.5 V; I <sub>IK</sub> = -18 mA		-0.9	-1.2		-1.2	V
V <sub>OH</sub>	HIGH-level output voltage	V <sub>CC</sub> = 4.5 V; I <sub>OH</sub> = -3 mA; V <sub>I</sub> = V <sub>IL</sub> or V <sub>IH</sub>	2.5	3.5		2.5		V
		V <sub>CC</sub> = 5.0 V; I <sub>OH</sub> = -3 mA; V <sub>I</sub> = V <sub>IL</sub> or V <sub>IH</sub>	3.0	4.0		3.0		V
		V <sub>CC</sub> = 4.5 V; I <sub>OH</sub> = -32 mA; V <sub>I</sub> = V <sub>IL</sub> or V <sub>IH</sub>	2.0	2.6		2.0		V
V <sub>OL</sub>	LOW-level output voltage	V <sub>CC</sub> = 4.5 V; I <sub>OL</sub> = 64 mA; V <sub>I</sub> = V <sub>IL</sub> or V <sub>IH</sub>		0.42	0.55		0.55	V
I <sub>I</sub>	Input leakage current	Control pins V <sub>CC</sub> = 5.5 V; V <sub>I</sub> = GND or 5.5 V		±0.01	±1.0		±1.0	µA
		Data pins V <sub>CC</sub> = 5.5 V; V <sub>I</sub> = GND or 5.5 V		±5	±100		±100	µA
I <sub>OFF</sub>	Power-off leakage current	V <sub>CC</sub> = 0 V; V <sub>O</sub> or V <sub>I</sub> ≤ 4.5 V		±5.0	±100		±100	µA
I <sub>PU/</sub> PD	Power-up/down 3-State output current <sup>3</sup>	V <sub>CC</sub> = 2.0 V; V <sub>O</sub> = 0.5 V; V <sub>I</sub> = GND or V <sub>CC</sub> ; V <sub>OE</sub> = V <sub>CC</sub>		±5.0	±50		±50	µA
I <sub>IH</sub> + I <sub>OZH</sub>	3-State output HIGH current	V <sub>CC</sub> = 5.5 V; V <sub>O</sub> = 2.7 V; V <sub>I</sub> = V <sub>IL</sub> or V <sub>IH</sub>		5.0	50		50	µA
I <sub>IL</sub> + I <sub>OZL</sub>	3-State output LOW current	V <sub>CC</sub> = 5.5 V; V <sub>O</sub> = 0.5 V; V <sub>I</sub> = V <sub>IL</sub> or V <sub>IH</sub>		-5.0	-50		-50	µA
I <sub>C</sub> EX	Output HIGH leakage current	V <sub>CC</sub> = 5.5 V; V <sub>O</sub> = 5.5 V; V <sub>I</sub> = GND or V <sub>CC</sub>		5.0	50		50	µA
I <sub>O</sub>	Output current <sup>1</sup>	V <sub>CC</sub> = 5.5 V; V <sub>O</sub> = 2.5 V	-50	-80	-180	-50	-180	mA
I <sub>C</sub> CH	Quiescent supply current	V <sub>CC</sub> = 5.5 V; Outputs HIGH; V <sub>I</sub> = GND or V <sub>CC</sub>		0.5	250		250	µA
I <sub>C</sub> CL		V <sub>CC</sub> = 5.5 V; Outputs LOW; V <sub>I</sub> = GND or V <sub>CC</sub>		20	30		30	mA
I <sub>C</sub> ZZ		V <sub>CC</sub> = 5.5 V; Outputs 3-State; V <sub>I</sub> = GND or V <sub>CC</sub>		0.5	250		250	µA
ΔI <sub>CC</sub>	Additional supply current per input pin <sup>2</sup>	Outputs enabled, one data input at 3.4 V, other inputs at V <sub>CC</sub> or GND; V <sub>CC</sub> = 5.5 V		0.5	1.5		1.5	mA
		Outputs 3-State, one data input at 3.4 V, other inputs at V <sub>CC</sub> or GND; V <sub>CC</sub> = 5.5 V		50	250		250	µA
		Outputs 3-State, one enable input at 3.4 V, other inputs at V <sub>CC</sub> or GND; V <sub>CC</sub> = 5.5 V		0.5	1.5		1.5	mA

### NOTES:

- Not more than one output should be tested at a time, and the duration of the test should not exceed one second.
- This is the increase in supply current for each input at 3.4 V.
- This parameter is valid for any V<sub>CC</sub> between 0 V and 2.1 V with a transition time of up to 10 msec. For V<sub>CC</sub> = 2.1 V to V<sub>CC</sub> = 5 V ± 10 %, a transition time of up to 100 µsec is permitted.

# Octal transceiver with parity generator/checker (3-State)

74ABT657

## AC CHARACTERISTICS

GND = 0 V;  $t_R = t_F = 2.5$  ns;  $C_L = 50$  pF,  $R_L = 500$   $\Omega$

SYMBOL	PARAMETER	WAVEFORMS	LIMITS					UNIT
			$T_{amb} = +25$ °C $V_{CC} = +5.0$ V			$T_{amb} = -40$ °C to $+85$ °C $V_{CC} = +5.0$ V $\pm$ 10 %		
			Min	Typ	Max	Min	Max	
$t_{PLH}$ $t_{PHL}$	Propagation delay An to Bn or Bn to An	2	1.1 1.2	2.5 3.0	4.1 3.9	1.1 1.2	4.6 4.3	ns
$t_{PLH}$ $t_{PHL}$	Propagation delay An to PARITY	1, 2	2.5 2.8	5.1 5.0	6.7 7.4	2.5 2.8	8.1 8.9	ns
$t_{PLH}$ $t_{PHL}$	Propagation delay ODD/EVEN to PARITY, ERROR	1, 2	1.7 1.9	3.5 3.7	4.6 5.1	1.7 1.9	5.3 5.8	ns
$t_{PLH}$ $t_{PHL}$	Propagation delay Bn to ERROR	1, 2	3.9 4.0	7.3 7.9	10.2 10.5	3.9 4.0	12.3 12.9	ns
$t_{PLH}$ $t_{PHL}$	Propagation delay PARITY to ERROR	1, 2	2.7 3.2	4.5 5.2	5.9 6.7	2.7 3.2	7.7 8.1	ns
$t_{PZH}$ $t_{PZL}$	Output enable time <sup>1</sup> to HIGH or LOW level	3, 4	1.3 1.9	3.6 4.2	5.5 5.3	1.3 1.9	6.5 6.5	ns
$t_{PHZ}$ $t_{PLZ}$	Output disable time from HIGH or LOW level	3, 4	2.4 2.2	3.6 3.4	5.6 7.3	2.4 2.2	6.2 7.8	ns

### NOTES:

- These delay times reflect the 3-State recovery time only and do not include the delay through the buffers and the parity check circuitry which affect the ERROR output. To assure valid information at the ERROR pin, time must be allowed for the signal to propagate through the drivers (B to A), through the parity check circuitry (same as A to PARITY), and to the ERROR output.  
Valid data at the ERROR pin  $\geq$  (B to A) + (A to PARITY).

## AC WAVEFORMS

NOTE: For all waveforms,  $V_M = 1.5$  V.

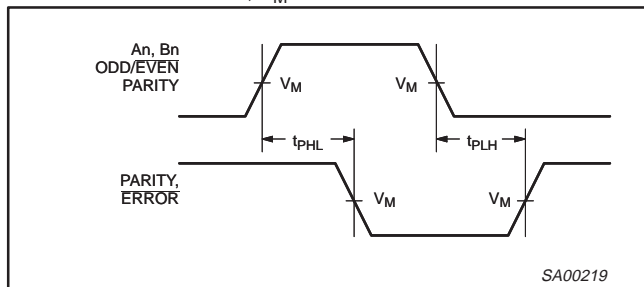

Waveform 1. Propagation delay for inverting output

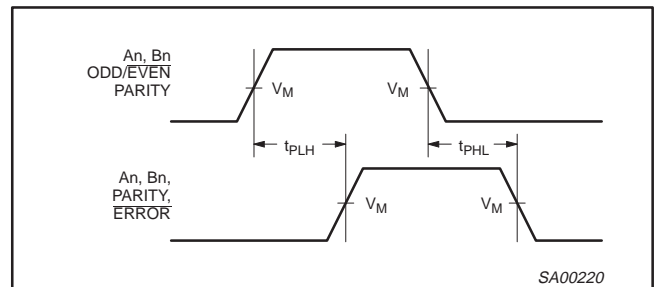

Waveform 2. Propagation delay For non-inverting output

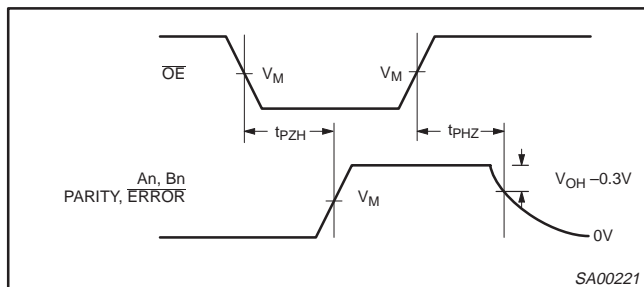

Waveform 3. 3-State Output Enable time to HIGH level and Output Disable time from HIGH level

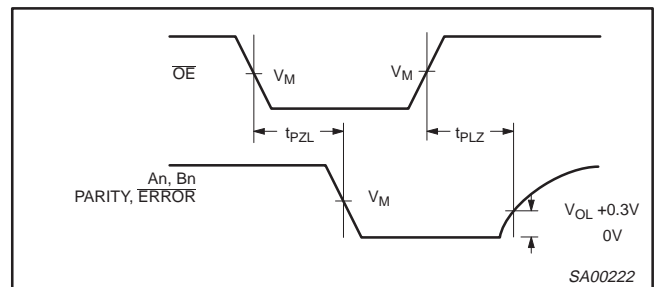

Waveform 4. 3-State Output Enable time to LOW level and Output Disable time from LOW level

# Octal transceiver with parity generator/checker (3-State)

74ABT657

## TEST CIRCUIT AND WAVEFORM

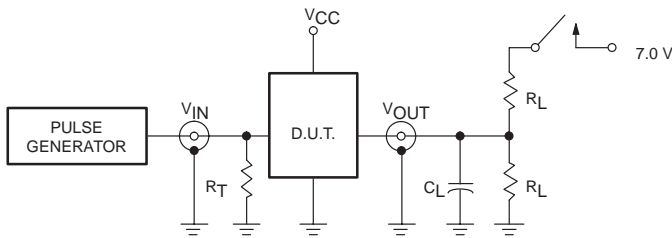

Test Circuit for 3-State Outputs

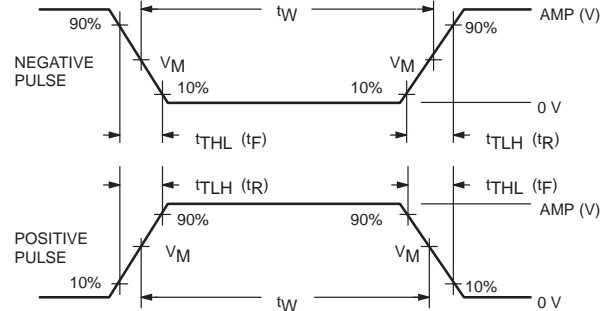

$V_M = 1.5\text{ V}$   
Input Pulse Definition

### SWITCH POSITION

TEST	SWITCH
$t_{PLZ}$	closed
$t_{pZL}$	closed
All other	open

### DEFINITIONS

$R_L$  = Load resistor; see AC CHARACTERISTICS for value.  
 $C_L$  = Load capacitance includes jig and probe capacitance; see AC CHARACTERISTICS for value.  
 $R_T$  = Termination resistance should be equal to  $Z_{OUT}$  of pulse generators.

FAMILY	INPUT PULSE REQUIREMENTS				
	Amplitude	Rep. Rate	$t_W$	$t_R$	$t_F$
74ABT	3.0 V	1 MHz	500 ns	2.5 ns	2.5 ns

SA00660



# Octal transceiver with parity generator/checker (3-State)

74ABT657

SO24: plastic small outline package; 24 leads; body width 7.5 mm

SOT137-1

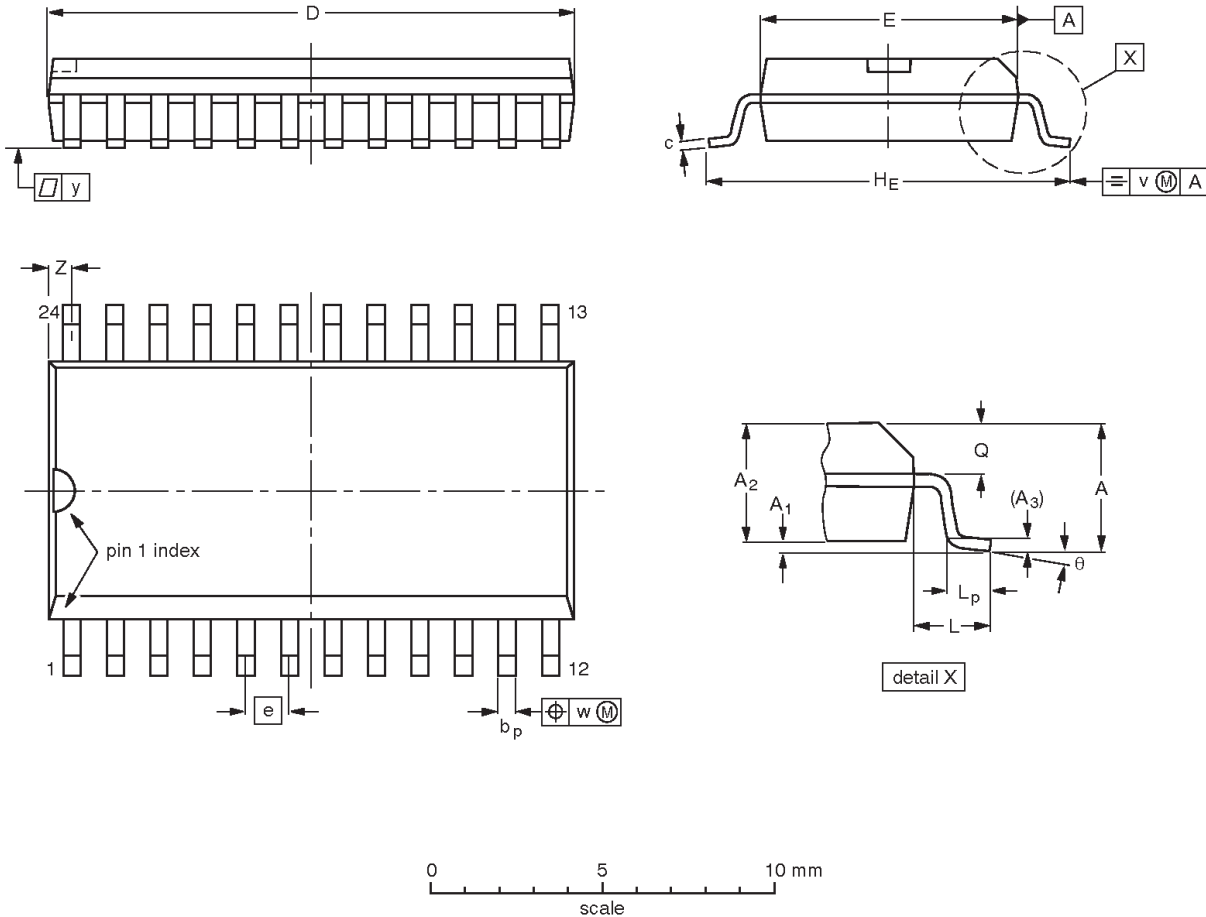

**DIMENSIONS (inch dimensions are derived from the original mm dimensions)**

UNIT	A max.	A <sub>1</sub>	A <sub>2</sub>	A <sub>3</sub>	b <sub>p</sub>	c	D <sup>(1)</sup>	E <sup>(1)</sup>	e	H <sub>E</sub>	L	L <sub>p</sub>	Q	v	w	y	Z <sup>(1)</sup>	θ
mm	2.65	0.3 0.1	2.45 2.25	0.25	0.49 0.36	0.32 0.23	15.6 15.2	7.6 7.4	1.27	10.65 10.00	1.4	1.1 0.4	1.1 1.0	0.25	0.25	0.1	0.9 0.4	8° 0°
inches	0.1	0.012 0.004	0.096 0.089	0.01	0.019 0.014	0.013 0.009	0.61 0.60	0.30 0.29	0.05	0.419 0.394	0.055	0.043 0.016	0.043 0.039	0.01	0.01	0.004	0.035 0.016	

**Note**

1. Plastic or metal protrusions of 0.15 mm (0.006 inch) maximum per side are not included.

OUTLINE VERSION	REFERENCES				EUROPEAN PROJECTION	ISSUE DATE
	IEC	JEDEC	JEITA			
SOT137-1	075E05	MS-013				-99-12-27 03-02-19

# Octal transceiver with parity generator/checker (3-State)

74ABT657

SSOP24: plastic shrink small outline package; 24 leads; body width 5.3 mm

SOT340-1

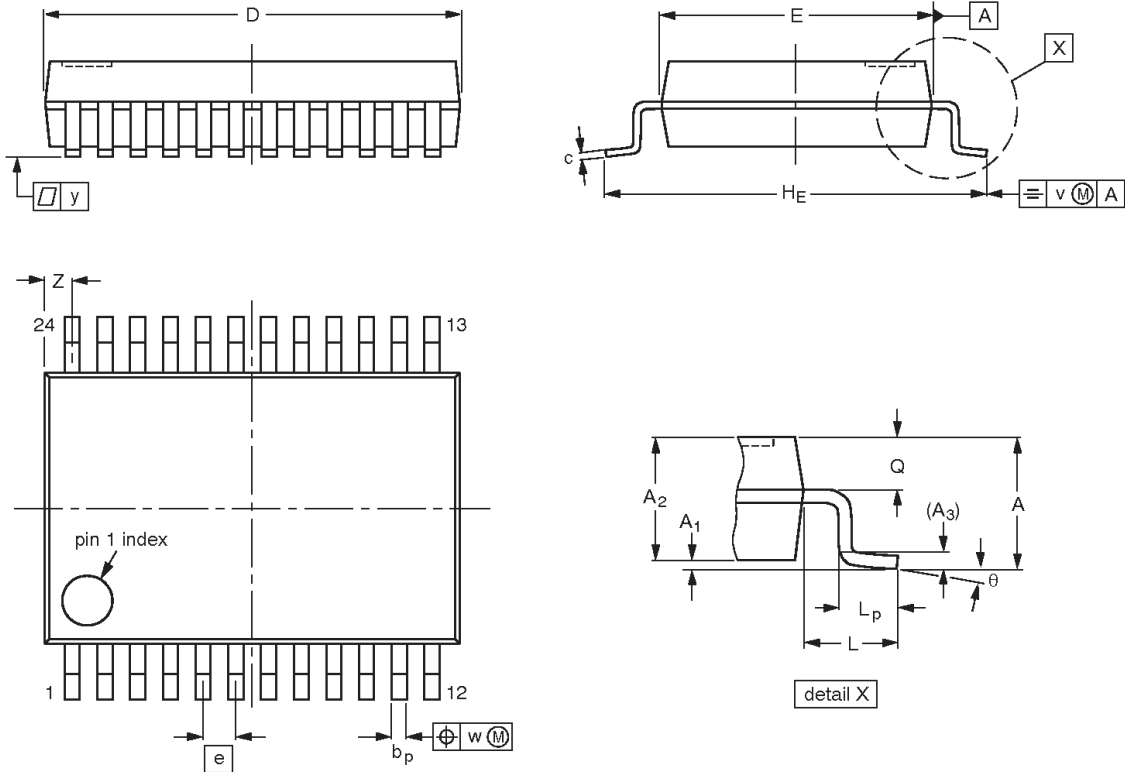

**DIMENSIONS (mm are the original dimensions)**

UNIT	A max.	A <sub>1</sub>	A <sub>2</sub>	A <sub>3</sub>	b <sub>p</sub>	c	D <sup>(1)</sup>	E <sup>(1)</sup>	e	HE	L	L <sub>p</sub>	Q	v	w	y	Z <sup>(1)</sup>	θ
mm	2	0.21 0.05	1.80 1.65	0.25	0.38 0.25	0.20 0.09	8.4 8.0	5.4 5.2	0.65	7.9 7.6	1.25	1.03 0.63	0.9 0.7	0.2	0.13	0.1	0.8 0.4	8° 0°

**Note**

1. Plastic or metal protrusions of 0.2 mm maximum per side are not included.

OUTLINE VERSION	REFERENCES				EUROPEAN PROJECTION	ISSUE DATE
	IEC	JEDEC	JEITA			
SOT340-1		MO-150				99-12-27 03-02-19

# Octal transceiver with parity generator/checker (3-State)

74ABT657

DIP24: plastic dual in-line package; 24 leads (300 mil)

SOT222-1

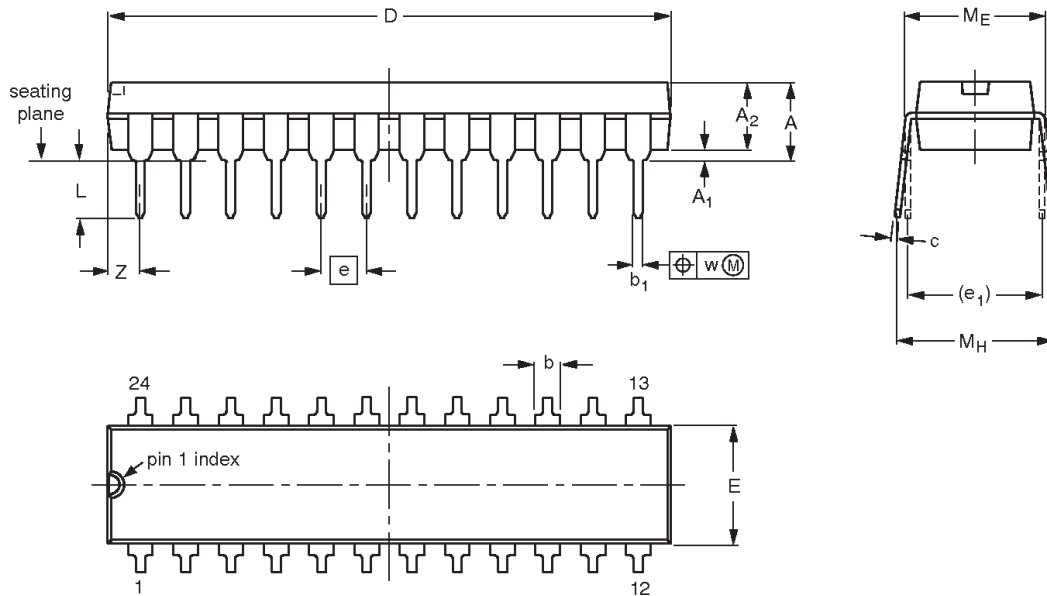

**DIMENSIONS (mm dimensions are derived from the original inch dimensions)**

UNIT	A max.	A <sub>1</sub> min.	A <sub>2</sub> max.	b	b <sub>1</sub>	c	D <sup>(1)</sup>	E <sup>(1)</sup>	e	e <sub>1</sub>	L	M <sub>E</sub>	M <sub>H</sub>	w	Z <sup>(1)</sup> max.
mm	4.7	0.38	3.94	1.63 1.14	0.56 0.43	0.36 0.25	31.9 31.5	6.73 6.25	2.54	7.62	3.51 3.05	8.13 7.62	10.03 7.62	0.25	2.05
inches	0.185	0.015	0.155	0.064 0.045	0.022 0.017	0.014 0.010	1.256 1.240	0.265 0.246	0.1	0.3	0.138 0.120	0.32 0.30	0.395 0.300	0.01	0.081

**Note**

1. Plastic or metal protrusions of 0.25 mm (0.01 inch) maximum per side are not included.

OUTLINE VERSION	REFERENCES				EUROPEAN PROJECTION	ISSUE DATE
	IEC	JEDEC	JEITA			
SOT222-1		MS-001				<del>99-12-27</del> 03-03-12

# Octal transceiver with parity generator/checker (3-State)

74ABT657

TSSOP24: plastic thin shrink small outline package; 24 leads; body width 4.4 mm

SOT355-1

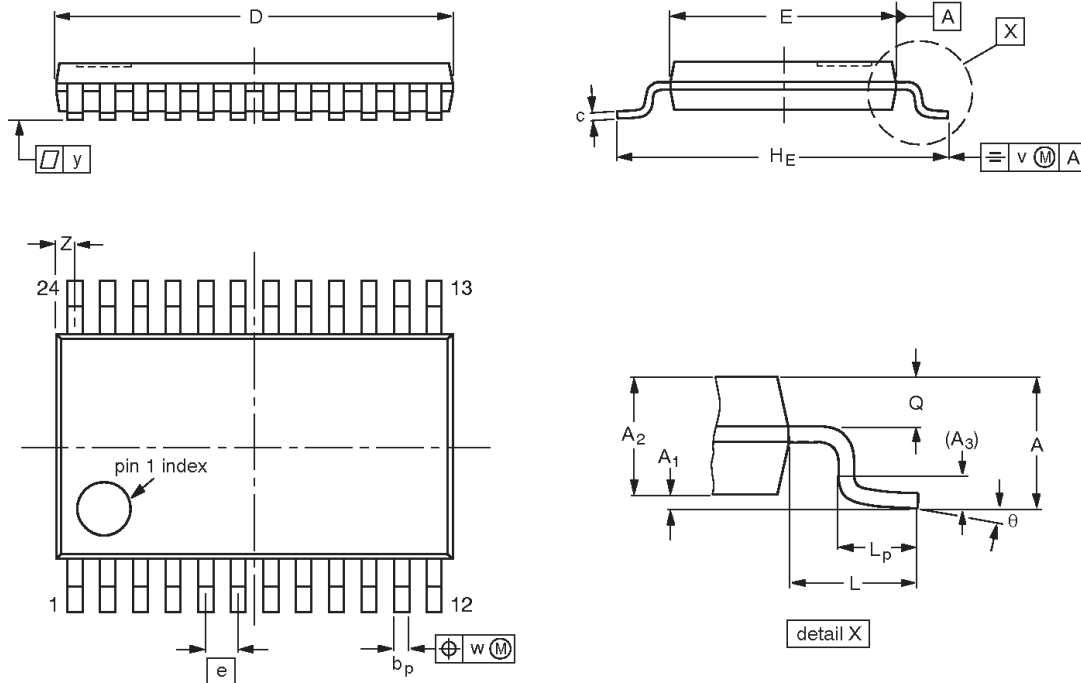

**DIMENSIONS (mm are the original dimensions)**

UNIT	A max.	A <sub>1</sub>	A <sub>2</sub>	A <sub>3</sub>	b <sub>p</sub>	c	D <sup>(1)</sup>	E <sup>(2)</sup>	e	H <sub>E</sub>	L	L <sub>p</sub>	Q	v	w	y	Z <sup>(1)</sup>	θ
mm	1.1	0.15 0.05	0.95 0.80	0.25	0.30 0.19	0.2 0.1	7.9 7.7	4.5 4.3	0.65	6.6 6.2	1	0.75 0.50	0.4 0.3	0.2	0.13	0.1	0.5 0.2	8° 0°

**Notes**

1. Plastic or metal protrusions of 0.15 mm maximum per side are not included.
2. Plastic interlead protrusions of 0.25 mm maximum per side are not included.

OUTLINE VERSION	REFERENCES				EUROPEAN PROJECTION	ISSUE DATE
	IEC	JEDEC	JEITA			
SOT355-1		MO-153				-99-12-27 03-02-19

# Octal transceiver with parity generator/checker (3-State)

74ABT657

## REVISION HISTORY

Rev	Date	Description
_2	20041027	<p><b>Product data sheet (9397 750 14239). Supersedes data of 1995 Dec 11.</b></p> <p>Modifications:</p> <ul style="list-style-type: none"> <li>● Ordering information table on page 2: <ul style="list-style-type: none"> <li>– Removed “North America” column; renamed column “Outside North America” to “Order Code”</li> </ul> </li> <li>● AC Characteristics table on page 7: <ul style="list-style-type: none"> <li>– Propagation delay An to Bn or Bn to An <ul style="list-style-type: none"> <li><math>T_{amb} = 25\text{ }^{\circ}\text{C}; V_{CC} = +5.0\text{ V}</math>: <ul style="list-style-type: none"> <li>changed <math>t_{PLH(typ)}</math> from 3.3 ns to 2.5 ns; <math>t_{PLH(max)}</math> changed from 5.0 ns to 4.1 ns</li> <li>changed <math>t_{PHL(max)}</math> from 4.3 ns to 3.9 ns</li> </ul> </li> <li><math>T_{amb} = -40\text{ }^{\circ}\text{C to }+85\text{ }^{\circ}\text{C}; V_{CC} = +5.0\text{ V} \pm 10\%</math>: <ul style="list-style-type: none"> <li>changed <math>t_{PLH(max)}</math> from 5.5 ns to 4.6 ns; changed <math>t_{PHL(max)}</math> from 4.8 ns to 4.3 ns</li> </ul> </li> </ul> </li> <li>– Propagation delay An to PARITY <ul style="list-style-type: none"> <li><math>T_{amb} = 25\text{ }^{\circ}\text{C}; V_{CC} = +5.0\text{ V}</math>: <ul style="list-style-type: none"> <li>changed <math>t_{PLH(typ)}</math> from 6.5 ns to 5.1 ns; <math>t_{PLH(max)}</math> changed from 8.7 ns to 6.7 ns</li> <li>changed <math>t_{PHL(typ)}</math> from 7.0 ns to 5.0 ns; changed <math>t_{PHL(max)}</math> from 9.1 ns to 7.4 ns</li> </ul> </li> <li><math>T_{amb} = -40\text{ }^{\circ}\text{C to }+85\text{ }^{\circ}\text{C}; V_{CC} = +5.0\text{ V} \pm 10\%</math>: <ul style="list-style-type: none"> <li>changed <math>t_{PLH(max)}</math> from 10.1 ns to 8.1 ns; changed <math>t_{PHL(max)}</math> from 10.6 ns to 8.9 ns</li> </ul> </li> </ul> </li> <li>– Propagation delay ODD/EVEN to PARITY, ERROR <ul style="list-style-type: none"> <li><math>T_{amb} = 25\text{ }^{\circ}\text{C}; V_{CC} = +5.0\text{ V}</math>: <ul style="list-style-type: none"> <li>changed <math>t_{PLH(typ)}</math> from 5.0 ns to 3.5 ns; <math>t_{PLH(max)}</math> changed from 6.6 ns to 4.6 ns</li> <li>changed <math>t_{PHL(typ)}</math> from 5.0 ns to 3.7 ns; changed <math>t_{PHL(max)}</math> from 6.6 ns to 5.1 ns</li> </ul> </li> <li><math>T_{amb} = -40\text{ }^{\circ}\text{C to }+85\text{ }^{\circ}\text{C}; V_{CC} = +5.0\text{ V} \pm 10\%</math>: <ul style="list-style-type: none"> <li>changed <math>t_{PLH(max)}</math> from 7.3 ns to 5.3 ns; changed <math>t_{PHL(max)}</math> from 7.3 ns to 5.8 ns</li> </ul> </li> </ul> </li> <li>– Propagation delay Bn to ERROR <ul style="list-style-type: none"> <li><math>T_{amb} = 25\text{ }^{\circ}\text{C}; V_{CC} = +5.0\text{ V}</math>: <ul style="list-style-type: none"> <li>changed <math>t_{PLH(typ)}</math> from 9.2 ns to 7.3 ns; <math>t_{PLH(max)}</math> changed from 11.7 ns to 10.2 ns</li> <li>changed <math>t_{PHL(typ)}</math> from 9.6 ns to 7.9 ns; changed <math>t_{PHL(max)}</math> from 12.1 ns to 10.5 ns</li> </ul> </li> <li><math>T_{amb} = -40\text{ }^{\circ}\text{C to }+85\text{ }^{\circ}\text{C}; V_{CC} = +5.0\text{ V} \pm 10\%</math>: <ul style="list-style-type: none"> <li>changed <math>t_{PLH(max)}</math> from 13.8 ns to 12.3 ns; changed <math>t_{PHL(max)}</math> from 14.5 ns to 12.9 ns</li> </ul> </li> </ul> </li> <li>– Propagation delay PARITY to ERROR <ul style="list-style-type: none"> <li><math>T_{amb} = 25\text{ }^{\circ}\text{C}; V_{CC} = +5.0\text{ V}</math>: <ul style="list-style-type: none"> <li>changed <math>t_{PLH(typ)}</math> from 6.0 ns to 4.5 ns; <math>t_{PLH(max)}</math> changed from 7.6 ns to 5.9 ns</li> <li>changed <math>t_{PHL(typ)}</math> from 6.4 ns to 5.2 ns; changed <math>t_{PHL(max)}</math> from 8.0 ns to 6.7 ns</li> </ul> </li> <li><math>T_{amb} = -40\text{ }^{\circ}\text{C to }+85\text{ }^{\circ}\text{C}; V_{CC} = +5.0\text{ V} \pm 10\%</math>: <ul style="list-style-type: none"> <li>changed <math>t_{PLH(max)}</math> from 9.4 ns to 7.7 ns; changed <math>t_{PHL(max)}</math> from 9.4 ns to 8.1 ns</li> </ul> </li> </ul> </li> <li>– Output enable time to HIGH or LOW level <ul style="list-style-type: none"> <li><math>T_{amb} = 25\text{ }^{\circ}\text{C}; V_{CC} = +5.0\text{ V}</math>: <ul style="list-style-type: none"> <li>changed <math>t_{PZH(typ)}</math> from 3.8 ns to 3.6 ns; <math>t_{PZH(max)}</math> changed from 5.6 ns to 5.5 ns</li> <li>changed <math>t_{PZL(typ)}</math> from 4.4 ns to 4.2 ns; changed <math>t_{PZL(max)}</math> from 7.0 ns to 5.3 ns</li> </ul> </li> <li><math>T_{amb} = -40\text{ }^{\circ}\text{C to }+85\text{ }^{\circ}\text{C}; V_{CC} = +5.0\text{ V} \pm 10\%</math>: <ul style="list-style-type: none"> <li>changed <math>t_{PZH(max)}</math> from 6.6 ns to 6.5 ns; changed <math>t_{PZL(max)}</math> from 8.2 ns to 6.5 ns</li> </ul> </li> </ul> </li> <li>– Output disable time from HIGH or LOW level <ul style="list-style-type: none"> <li><math>T_{amb} = 25\text{ }^{\circ}\text{C}; V_{CC} = +5.0\text{ V}</math>: <ul style="list-style-type: none"> <li>changed <math>t_{PHZ(typ)}</math> from 5.1 ns to 3.6 ns; <math>t_{PHZ(max)}</math> changed from 7.0 ns to 5.6 ns</li> <li>changed <math>t_{PLZ(min)}</math> from 2.7 ns to 2.2 ns; changed <math>t_{PLZ(typ)}</math> from 5.4 ns to 3.4 ns;</li> <li>changed <math>t_{PLZ(max)}</math> from 7.6 ns to 7.3 ns</li> </ul> </li> <li><math>T_{amb} = -40\text{ }^{\circ}\text{C to }+85\text{ }^{\circ}\text{C}; V_{CC} = +5.0\text{ V} \pm 10\%</math>: <ul style="list-style-type: none"> <li>changed <math>t_{PHZ(max)}</math> from 7.6 ns to 6.2 ns;</li> <li>changed <math>t_{PLZ(min)}</math> from 2.7 ns to 2.2 ns; changed <math>t_{PLZ(max)}</math> from 8.1 ns to 7.8 ns</li> </ul> </li> </ul> </li> </ul> <p>● Added Revision History table.</p> </li></ul>
_1	19951211	<b>Product specification. ECN 853-1615 16106 of 11 December 1995.</b>

# Octal transceiver with parity generator/checker (3-State)

74ABT657

## Data sheet status

Level	Data sheet status <sup>[1]</sup>	Product status <sup>[2] [3]</sup>	Definitions
I	Objective data sheet	Development	This data sheet contains data from the objective specification for product development. Philips Semiconductors reserves the right to change the specification in any manner without notice.
II	Preliminary data sheet	Qualification	This data sheet contains data from the preliminary specification. Supplementary data will be published at a later date. Philips Semiconductors reserves the right to change the specification without notice, in order to improve the design and supply the best possible product.
III	Product data sheet	Production	This data sheet contains data from the product specification. Philips Semiconductors reserves the right to make changes at any time in order to improve the design, manufacturing and supply. Relevant changes will be communicated via a Customer Product/Process Change Notification (CPCN).

[1] Please consult the most recently issued data sheet before initiating or completing a design.

[2] The product status of the device(s) described in this data sheet may have changed since this data sheet was published. The latest information is available on the Internet at URL <http://www.semiconductors.philips.com>.

[3] For data sheets describing multiple type numbers, the highest-level product status determines the data sheet status.

## Definitions

**Short-form specification** — The data in a short-form specification is extracted from a full data sheet with the same type number and title. For detailed information see the relevant data sheet or data handbook.

**Limiting values definition** — Limiting values given are in accordance with the Absolute Maximum Rating System (IEC 60134). Stress above one or more of the limiting values may cause permanent damage to the device. These are stress ratings only and operation of the device at these or at any other conditions above those given in the Characteristics sections of the specification is not implied. Exposure to limiting values for extended periods may affect device reliability.

**Application information** — Applications that are described herein for any of these products are for illustrative purposes only. Philips Semiconductors make no representation or warranty that such applications will be suitable for the specified use without further testing or modification.

## Disclaimers

**Life support** — These products are not designed for use in life support appliances, devices, or systems where malfunction of these products can reasonably be expected to result in personal injury. Philips Semiconductors customers using or selling these products for use in such applications do so at their own risk and agree to fully indemnify Philips Semiconductors for any damages resulting from such application.

**Right to make changes** — Philips Semiconductors reserves the right to make changes in the products—including circuits, standard cells, and/or software—described or contained herein in order to improve design and/or performance. When the product is in full production (status 'Production'), relevant changes will be communicated via a Customer Product/Process Change Notification (CPCN). Philips Semiconductors assumes no responsibility or liability for the use of any of these products, conveys no license or title under any patent, copyright, or mask work right to these products, and makes no representations or warranties that these products are free from patent, copyright, or mask work right infringement, unless otherwise specified.

## Contact information

For additional information please visit  
<http://www.semiconductors.philips.com>. Fax: +31 40 27 24825

© Koninklijke Philips Electronics N.V. 2004  
All rights reserved. Published in the U.S.A.

Date of release: 10-04

For sales offices addresses send e-mail to:  
[sales.addresses@www.semiconductors.philips.com](mailto:sales.addresses@www.semiconductors.philips.com)

Document number:

9397 750 14239

*Let's make things better.*